

PSXP PROFILE SYSTEM AUTOMATIC SLIDING DOOR



The GILGEN PSXP profile system sets the benchmark for automatic sliding doors, combining high quality components with intelligent Swiss design. Its modular construction allows for a high level of customisation to customers application needs ensuring the right impression is made everytime.

Although elegantly designed the profiles are robust and reliable, being tested to 1million cycles and the vertically interlocking configuration also provides protection from draughts. With sensors built into the header profile PSXP retains an attractive appearance suitable for design conscious environments.

Configurations

- Single-leaf and bi-parting sliding doors
- Two- and four-leaf telescopic sliding doors
- With side panel, glazed overhead panel and protection leaf
- Full-length bottom rail or fixed point guide
- Can be attached to the door lintel or wall

Security / Locking

- Floor lock / Hook lock
- Standard locking-system built into drive mechanism
- Optional multi-point locking - FLUVERI (integrated into door leaf) manual / automatic

Glazing & surface finish

- Safety glass ESG / VSG
- Insulated glass, glass thickness 6-24mm
- Plastic, aluminium, wood or composite infills
- Anodised - coloured or colourless
- Polyester powder coating to any RAL colour

Safety & Control

- Certified overall system (EN 16361)
- Independantly tested - TÜV Nord
- Compliance to EN 16005, DIN 18650 standards
- Integral safety with GILGEN SL
- Range of activation and control modules

Possible applications

Bi-parting installation with side panels

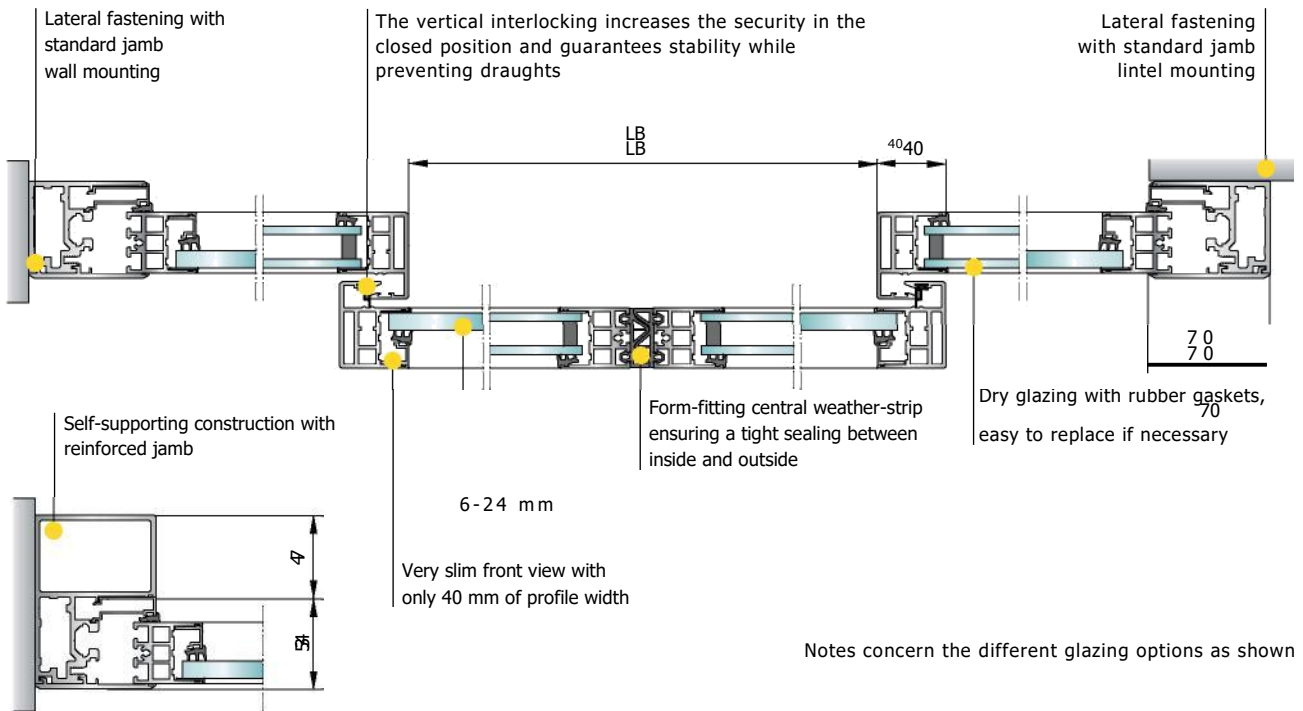

Single door leaf installation with side panel

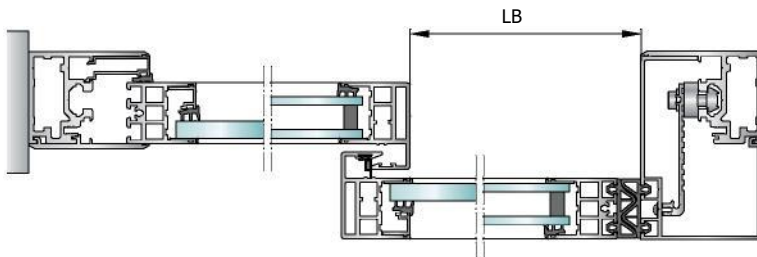

Four-leaf telescopic installation with side panels

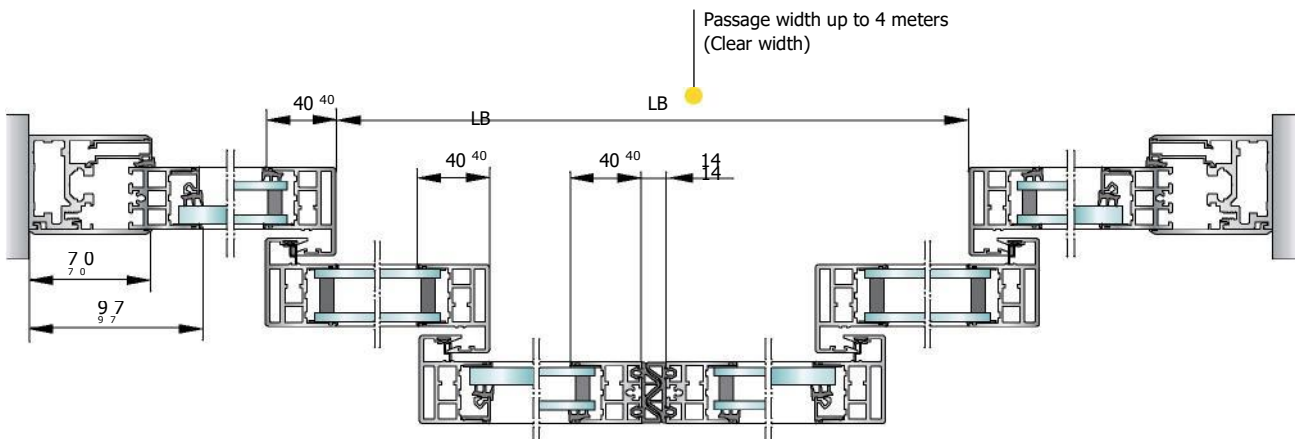

Header height of 100 mm and 140 mm

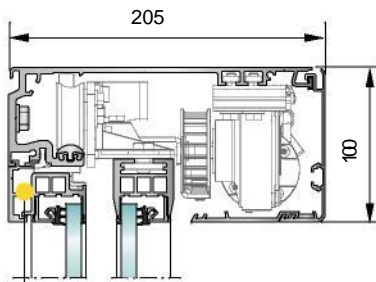

Header 100 mm
(possible with supporting profile)

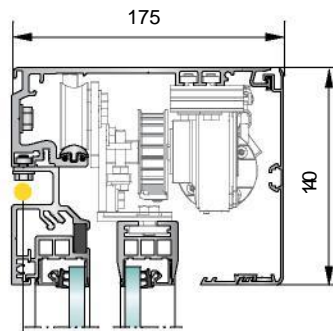

Header 140 mm
(possible with supporting profile)

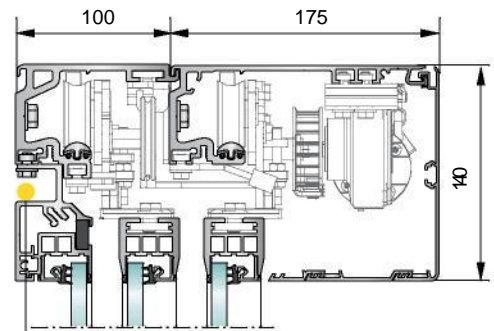

Header 140 mm telescopic
(possible with supporting profile)

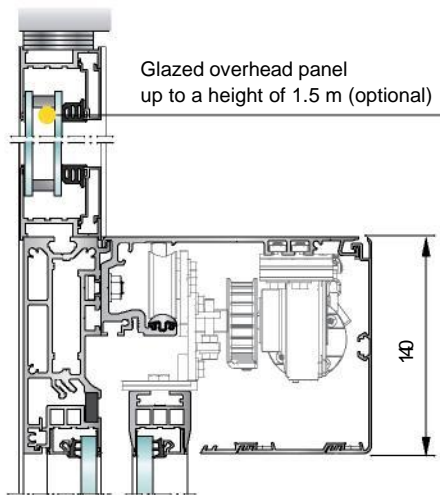

Glazed overhead panel
up to a height of 1.5 m (optional)

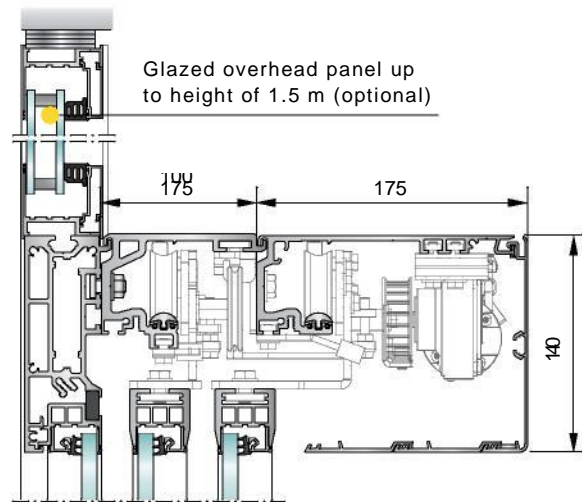

Glazed overhead panel up
to height of 1.5 m (optional)

Bottom guide rails

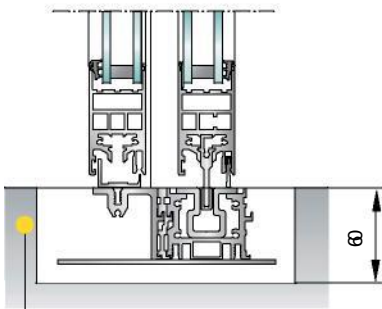

Full-length bottom rail integrated in the floor
(for increased safety and stability),
bottom rail with drainage optionally available

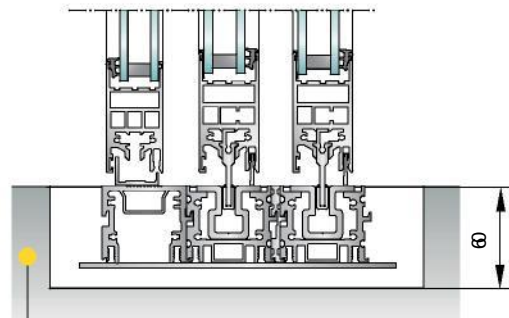

Full-length bottom rail telescopic,
bottom rail with drainage optionally available

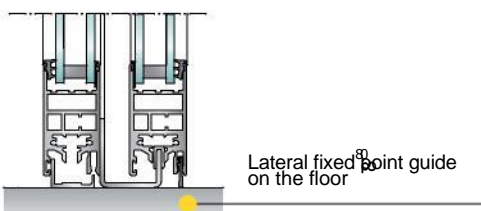

Lateral fixed point guide
on the floor

Range of application - PSXP Profile System

PSXP sliding door	Clear width	Clear height	max. door leaf weight
Single-leaf	700 - 2000 mm (redundant 950 - 2000 mm)	up to 3000 mm	150 kg
Bi-parting	800 - 3000 mm (redundant 900 - 3000 mm)	up to 3000 mm	2 x 150 kg
Two-leaf telescopic	1100 - 3000 mm (redundant 1100 - 3000 mm)	up to 3000 mm	2 x 120 kg
Four-leaf telescopic	1200 - 4000 mm (redundant 1200 - 4000 mm)	up to 3000 mm	4 x 75 kg

*Note: redundant configuration is not in common use in the UK. If required sizes may differ. Please contact us for advice.

Environmental performance as tested to product standard EN 16361



Air permeability*

- PPD 2



Wind resistance*

- PPD 600 B
- PPD 400 C



Watertightness*

- 5 A

* Depending on the size of the system and its configuration

Options

FLUVERI multipoint locking

- automatic or manual
- two-way interlocking of the door leaves, invisibly incorporated in the vertical profile
- Options
 - manual unlocking lever with cylinder
 - locking bolt engaging into the floor for manual version
 - lock monitoring

Hook lock

- manual single-point locking
- invisibly incorporated in the vertical profile

Manual floor lock

Midrail profile

- simple door leaf division
- for individual door leaf fillings

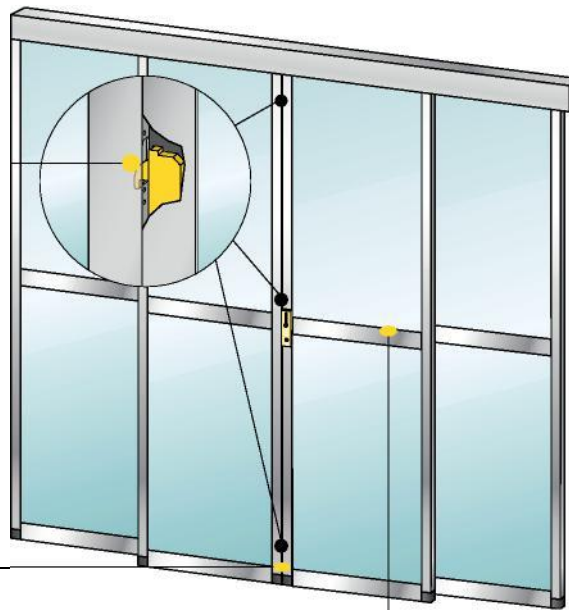

GDUK Door Solutions

Securiparc House, Wimsey Way, Alfreton, Derbys, DE55 4LS

Tel: 0800 316 6994, info@gdukds.com

www.gdukds.com